

# SITI

SPA

SOCIETÀ ITALIANA TRASMISSIONI INDUSTRIALI



I - MI - U - MU - MD

**Montage – Center**

**Max Lamb GmbH & Co. KG**

Am Bauhof

97076 Würzburg

Tel. 0931 / 2794 - 0

Fax. 0931 / 2794 - 261

email: [ant@lamb.de](mailto:ant@lamb.de)

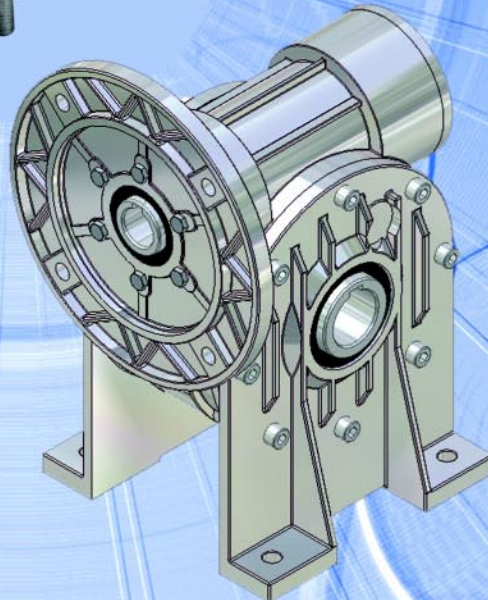
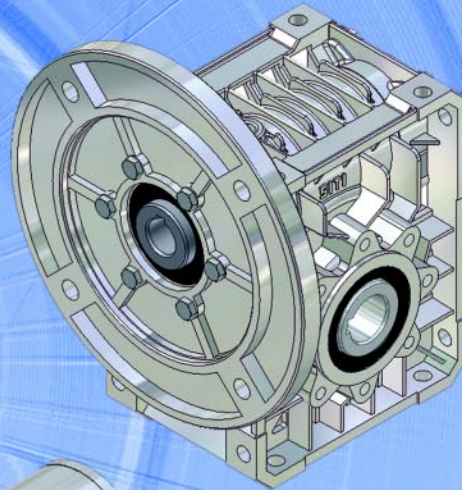
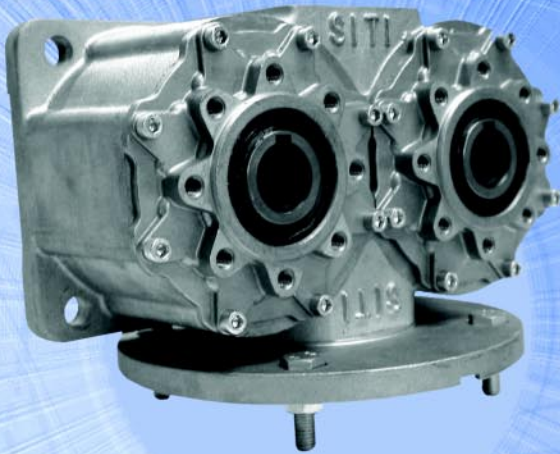
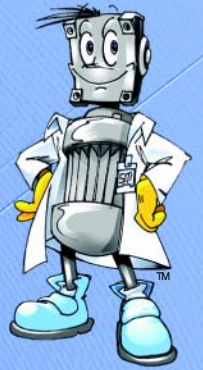

**INSTALLATION, OPERATION  
and MAINTENANCE MANUAL**

**09.2008**





We, at SITI S.p.A., would like to thank you for the confidence shown in choosing our products. Our dedication to quality and innovation have allowed us to develop highly efficient gearboxes capable of satisfying even the most demanding requirements.

Carefully reading and becoming familiar with the contents of this manual is of prime importance for trouble-free operation.

If, after thoroughly reading this manual, some topics are not clear please do not hesitate to contact our Customer Service Department or Service centers for more detailed information.

**Copyright. Unauthorized reproduction can result in civil damages and criminal prosecution. The contents of the manual and drawings are valuable trade secrets and must not be given to third parties, copied, reproduced, disclosed or transferred unless duly authorized by SITI S.p.A. in writing in advance.**

## MANUFACTURER'S DATA



## CONTACTING OUR SERVICE DEPARTMENT

When contacting our customer service department always quote the data indicated on the gearbox's identification plate.

## Contents

MANUFACTURER'S DATA .....	3
CONTACTING OUR SERVICE DEPARTMENT .....	3
<b>1 GENERAL INFORMATION .....</b>	<b>5</b>
1.1 CONTENTS OF THE MANUAL .....	5
1.2 USERS OF THE MANUAL .....	5
1.3 HOW TO CONSULT THE MANUAL .....	5
1.4 WORKING WITH THE USER .....	6
1.5 UPDATED VERSIONS OF THE MANUAL .....	6
1.6 SELECTING PERSONNEL AND PERSONNEL QUALIFICATION LEVELS .....	6
1.7 RESIDUAL RISKS .....	6
1.8 SALES CONDITIONS AND WARRANTY .....	6
<b>2 SAFETY INFORMATION .....</b>	<b>7</b>
2.1 GUIDELINES FOR USE IN POTENTIALLY EXPLOSIVE ATMOSPHERES .....	7
<b>3 DESCRIPTION .....</b>	<b>8</b>
3.1 INTENDED USE .....	8
3.2 FORBIDDEN AND ERRONEOUS USE .....	8
3.3 GEARBOX IDENTIFICATION DATA .....	8
3.3.1 HOW TO READ AND MAINTAIN THE PLATES .....	8
3.4 SPECIFICATIONS .....	8
<b>4 INSTALLATION INSTRUCTIONS .....</b>	<b>9</b>
4.1 OPERATIONS TO BE PERFORMED BEFORE INSTALLING THE GEARBOXES (BY THE CUSTOMER) .....	9
4.1.1 GEARBOX SHIPMENT, UNLOADING AND HANDLING .....	9
4.2 DECOMMISSIONING AND DISPOSAL .....	10
4.3 INSTALLATION INSTRUCTIONS .....	10
4.4 REDUCTION PAIRS INSTALLATION INSTRUCTIONS .....	10
4.5 TORQUE LIMITER INSTALLATION/OPERATING INSTRUCTIONS .....	10
<b>5 GEARBOX OPERATING INSTRUCTIONS .....</b>	<b>11</b>
5.1 IMPORTANT SAFETY INFORMATION .....	11
5.2 BEFORE STARTING THE GEARBOXES .....	12
5.3 DURING OPERATION .....	13
<b>6 MAINTENANCE .....</b>	<b>14</b>
6.1 ROUTINE AND SCHEDULED MAINTENANCE .....	14
6.2 CLEANING .....	14
6.3 OPERATING TEMPERATURE .....	14
6.4 MEASURING THE OPERATING TEMPERATURE .....	15
6.5 CHECKING THE LUBRICANT LEVEL .....	15
6.6 REPLACING THE SEALS .....	15
6.7 LUBRICATION .....	17
6.8 TIGHTENING TORQUE CHART .....	19
6.9 TROUBLESHOOTING GUIDE .....	20
<b>7 REPLACEMENT PARTS .....</b>	<b>20</b>

## 1 GENERAL INFORMATION

We, at SITI S.p.A., would like to thank you for choosing our products. Our dedication to quality and innovation have allowed us to develop highly efficient gearboxes capable of satisfying even the most demanding requirements.

Installation personnel must thoroughly read and familiarize themselves with the contents of this entire manual.

If in doubt, please do not hesitate to contact our Customer Service Department or Service centers for more detailed information.

### 1.1 CONTENTS OF THE MANUAL

This manual contains a description of the gearbox, information about “intended use” and performance along with the specifications and installation, operation and maintenance instructions.

### 1.2 USERS OF THE MANUAL

This publication is aimed at:

- the factory supervisor/installation personnel
- operators
- maintenance personnel

The person performing the job must keep the manual nearby where it can be easily consulted and kept in good condition. If the manual is lost or ruined, contact the MANUFACTURER to obtain another copy quoting the serial number of the gearbox.

### 1.3 HOW TO CONSULT THE MANUAL

The instructions are accompanied by icons that aid in reading the manual. In fact, these icons indicate the type of information provided, more precisely:



**Danger!**

**This icon indicates: failure to heed the safety standards and follow the instructions given may cause accidents. Carefully read and follow the instructions provided with this icon, exercising extreme caution at all times.**

 **This icon indicates important information on how to properly handle, install, use and maintain the gearbox.**



**This icon indicates the order given must be followed.**

When necessary the text includes the numbers of the figures that identify the illustrations provided in the manual. The parts of the gearbox described in the text are identified with numbers.

E.g.: - 1 - (fig. 1) means part of component 1 in figure 1.



In reference to ATEX standards.

## 1.4 WORKING WITH THE USER

The manufacturer is at the customer's disposal to answer any questions and provide any additional information needed. In addition we gladly accept any suggestions to improve this manual to make it more comprehensible and better satisfy the purposes it is designed for. If the equipment changes hands, please send the manufacturer the new owner's address so that he can receive any information, supplements and/or updates.

## 1.5 UPDATED VERSIONS OF THE MANUAL

This manual deals with the state-of-the-art condition of the gearbox it is in at the time it is put on the market. The manual is to be considered a fundamental part of the gearbox and complies with all laws, directives and standards currently in force. It cannot be considered inadequate only because updated later on based on new information. If any modifications, changes, etc.. are made to gearboxes sold later on the manufacturer shall not be held liable for modifying equipment previously supplied nor shall the gearbox and relative manual be considered incomplete and inadequate. Any supplements the manufacturer sends to the users should be kept along with the manual that is part of the gearbox.

**PROPER OPERATION AND TOP PERFORMANCE OF THE GEARBOX IS OBTAINED ONLY IF ALL THE INSTRUCTIONS GIVEN IN THIS MANUAL ARE CAREFULLY AND COMPLETELY FOLLOWED.**

## 1.6 SELECTING PERSONNEL AND PERSONNEL QUALIFICATION LEVELS

The operators responsible for handling, installing and servicing the gearboxes on their own must meet the requirements given below:

- minimum work age as specified by laws in force at the time of use
- well-educated and trained on how to properly and safely perform the jobs
- have completely read and become familiar with the contents of this manual
- have been instructed and fully understand the accident prevention laws in force at the time of use
- be physically able to carry out the jobs
- always wear certified personal safety gear

## 1.7 RESIDUAL RISKS

Assessment of the risks the operators responsible for operating and maintenance may face was carried out during the design stage. All the necessary precautions have been taken to make the machine safe and reliable. Risk assessment has not shown any particular residual risks.

## 1.8 SALES CONDITIONS AND WARRANTY

As regards all the commercial and legal aspects, consult the catalogue for the gearbox in question.

## 2 SAFETY INFORMATION

In compliance with Machinery Directive EEC 89/392 article 4.2 and annex 11/sub B, as the gearboxes dealt with in this certificate are incorporated and/or assembled in other machines they are considered “components” therefore:

THEY CANNOT BE STARTED UP UNTIL THE MACHINE THEY ARE INSTALLED IN HAS BEEN CERTIFIED THAT IT COMPLIES WITH MACHINERY DIRECTIVES 89/392/CEE, 91/368/CEE, 93/44/CEE AND 93/68/CEE.

**Note:**  
The product included in this certificate meets the essential requirements given above and those of the catalogue in force as of the date of production. SITI S.p.A. reserves the right to modify them according to changes in technology and materials.

- The gearbox must not be modified unless duly authorized by the manufacturer.
- Carefully read the instructions given in this manual before attempting to move the gearbox, especially when it weighs more than 25 kg.

### Warning!

Some gearboxes may be supplied without oil; they must be filled with oil immediately. Consult paragraph “6.7 Lubrication” for more specific information regarding the type and amount of lubricant required.



## 2.1 GUIDELINES FOR USE IN POTENTIALLY EXPLOSIVE ATMOSPHERES



Ignition can occur when mixes of flammable gases or dusts come into contact with hot parts of the gearboxes.



### Danger!

Only specially trained operators are authorized to install, connect, start up, carry out maintenance or repair the gearboxes. In any case, the steps below must be closely followed:

- Follow the instructions provided by the manufacturer.
- Observe the warning and alert symbols given on the gearboxes.
- Read and become familiar with the contents of the User's Manuals.
- Observe the specific standards for the plant.
- Observe the all standards currently in force (explosion protection, safety, risk prevention).

## 3 DESCRIPTION

### 3.1 INTENDED USE

The machine is designed for industrial use under normal environmental conditions specified by directive 94/9/EC (ATEX).

### 3.2 FORBIDDEN AND ERRONEOUS USE



The gearbox must not be used in areas whose environmental conditions are different from those specified below.

Group II

Category 2 G1/G2

Zone D 21-22

### 3.3 GEARBOX IDENTIFICATION DATA

All our gearboxes come with one or more plates that have the identification data stamped on them.

#### 3.3.1 HOW TO READ AND MAINTAIN THE PLATES

The data given on the plates must be legible at all times. Clean them on a regular basis. If a plate is worn and/or no longer legible, even if just one item, contact the manufacturer to obtain a replacement plate. When ordering, always quote the data given on the original plate.

Data contained on the nameplate:

- TYPE: Logo of the Gearbox.
- N° : Number
- RATIO: Reduction Ratio
- COD: Gearbox code-description
- ATEX Area
- File: Technical File Number

<b>SITI</b> ®		MADE IN ITALY www.sitiriduttori.it	
TIPO TYPE	<input type="text"/>		
N°	<input type="text"/>	RAPP. RATIO	<input type="text"/>
COD.	<input type="text"/>		
	IIGD1-21;2-22 T4-Tmax125° ck file		<input type="text"/>

#### Warning!

The plates must never be removed.

### 3.4 SPECIFICATIONS

#### Gearbox dimensions and performance

See the relative manual.

#### Airborne noise level

The airborne noise level when running under full load under the most adverse operating conditions is still considerably lower than 85 dB.



## 4 INSTALLATION INSTRUCTIONS

The worm gearboxes are delivered entirely factory assembled. Only specially trained personnel are authorized to install, assemble and start them up.

### 4.1 OPERATIONS TO BE PERFORMED BEFORE INSTALLING THE GEARBOXES (BY THE CUSTOMER)

#### Preparation

In order to install the gearbox, carry out the operations given on the confirmation before hand:

- Make sure the structures are adequate in relation to the actions and reactions deriving from use of the gearbox.
- Make sure the installation site is adequate and enough space is available.
- Make sure that the mounting position indicated in the order confirmation corresponds to the requested one.

#### 4.1.1 GEARBOX SHIPMENT, UNLOADING AND HANDLING

Always check the goods to make sure they were not broken or damaged during shipment before handling the gearbox.



**Danger!**

**The gearbox is delivered factory assembled and packed.**

**If the product is packed in cardboard cases, use lift equipment that complies with safety regulations to handle the product.**

To handle unpacked products, use lift equipment suitable for weights heavier than **30 kg**. In any case, pay careful attention not to accidentally bang surfaces and coupling parts. Use the eyebolt when needed (parts heavier than **30 kg**).

The eyebolt can lift just the gearbox and not the parts it will be attached to. Regarding gearboxes that weigh more than **30 kg** not equipped with an eyebolt, a suitable eyebolt should be used to lift them in complete safety. Otherwise exercise extreme caution and use slings to lift the gearboxes.

The types of eyebolts are given in the chart.

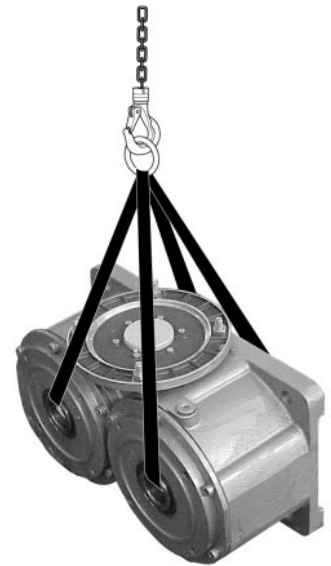

EYEBOLTS	
I 130	M10
I 150	M12
I 175	M12

## 4.2 DECOMMISSIONING AND DISPOSAL

When the gearbox has reached the end of its expected service life, it should be disassembled and disposed of. Drain the lubricant from the gearbox. Remember that oil greatly pollutes the environment.

Once decommissioned, dispose of the materials and oil in compliance with current environmental protection laws and standards.

Specialised companies should be contacted when disposing of materials. The user is responsible for assuring the company contracted is authorized and certified to handle toxic materials.

## 4.3 INSTALLATION INSTRUCTIONS

The position in which the gearbox is to be installed is given in the commercial catalogue.

## 4.4 REDUCTION PAIRS INSTALLATION INSTRUCTIONS

Installation instructions are provided inside the packaging.



## 4.5 TORQUE LIMITER INSTALLATION/OPERATING INSTRUCTIONS

The gearbox with built-in torque limiter is a gearbox provided with an internal clutch which can be adjusted from outside by means of a ring-nut.

This means that the torque can be varied.

The main feature of this device is that it is possible to stop the gearbox output shaft rotating when the torque exceeds the value set for the built-in torque limiter.

This prevents the machine parts connected to the gearbox from being damaged by overtorque and also prolongs the service life of the gearbox itself.

Bronze gear wheel **1** is not integral with the hub but is installed on two tapered seatings on output shaft **2** of the gearbox.

The drive force required is provided by the pressure exerted by Belleville washer **3** which, in turn, can be adjusted from outside by means of ring-nut **4**.

The parts of the torque limiter are oil bath-lubricated to ensure the torque is as constant as possible.

To adjust the torque:

- bend tooth **5** of the lock washer;
- turn ring-nut **4** clockwise to increase the torque or anti-clockwise to decrease it;
- bend the washer tooth back again.

The graph below shows the torque values for each gearbox size according to the number of ring-nut turns.

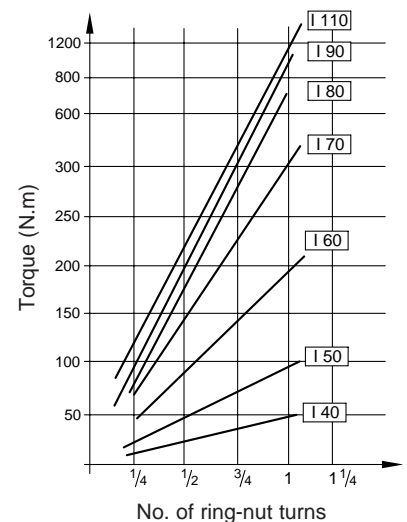
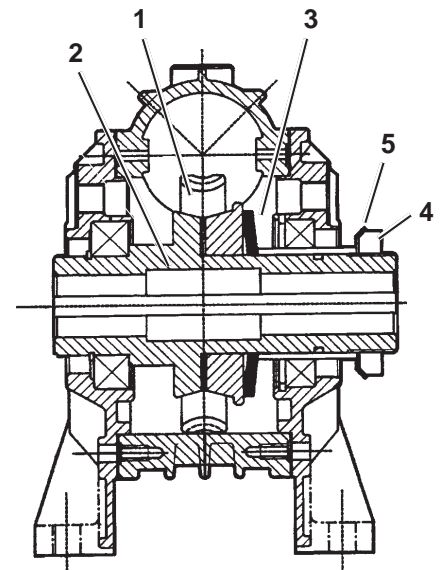

## 5 GEARBOX OPERATING INSTRUCTIONS

### 5.1 IMPORTANT SAFETY INFORMATION

Make certain the following requirements are observed when installing the gearbox:

During installation the following must NOT be present: potentially explosive atmosphere, oils, acids, vapors, radiation.



**The position in which the gearbox is installed can be changed only after contacting the manufacturer. The gearbox shall not be considered in compliance with the ATEX directive if the manufacturer is not contacted.**

Plastic inserts should be placed between the gearbox and drive (connection between different metals) if there is risk of chemical corrosion.

In addition, use plastic washers with the bolts! The plastic used should have a < 10<sup>9</sup>W capacity to withstand electric loss. Effectively ground the external structure. In addition use screws with motor earth for geared motors. Make sure enough air flows to cool down the gearbox and that warm air does not flow back from other devices. The temperature of the cooling air should not exceed 40 °C.



**Danger!**

**Only specially-trained personnel are authorized to install and start up the gearboxes. Incorrect installation may put the operator's safety at jeopardy and seriously or irreparably damage the equipment and machine it is connected to.**

Carefully follow the precautions given below:

Before attempting to carry out any operations, make certain the plant or drive motor is disconnected from the supply mains and that the machine is not energized.

Remember that the gearbox should never be operated without oil or when its parts are disconnected. In addition, do not put the gearbox in water or corrosive solutions.

Make sure the amount of lubricant, its viscosity index and position of the filler and drain plugs are adequate for the position in which the gearbox is installed and operating conditions present. In addition, do not use toxic oils and never mix two different types of oils together.

When installing the gearbox, always leave enough room free so that it can be periodically checked and maintenance can be conveniently performed. It is also important that air is able to flow freely to assure good ventilation and heat dispersion. The product should be installed in the position indicated on the order.



**Danger!**

**Make sure the gearbox is well-secured to the framework to assure vibration-free operation. In addition, it should be mounted on machined surfaces. Use systems that prevent the clamp screws from coming loose.**

Be extremely careful to perfectly align the gearbox with the motor and machine to be driven. Use flexible or self-aligning couplings where possible. If the gearbox risks being hit, overloaded for a prolonged time or blocked, install overload cut-outs, torque limiters, hydraulic couplings or other similar devices.

## 5.2 BEFORE STARTING THE GEARBOXES



### Measure the oil and surface temperature

The highest allowable surface temperature given in this manual was determined under normal environmental conditions. Even slight changes in these conditions (example: with service factors = 1) may considerably affect the temperature. When starting the gearbox, the surface temperature must be measured under maximum load.

Off-shelf thermometers may be used to measure the temperature.

The surface temperature must be measured in the area between the gearbox and motor where the clamps do not allow adequate air flow to cool down the motor fan.

The highest allowable surface temperature is reached after approximately three hours of operation and **must not exceed 50 °C (differential value)** in relation to the room temperature.

If this temperature (differential value) is exceeded, immediately stop the gearbox and contact the manufacturer.

### Checks to be performed

The chart given below lists all the checks to be made before attempting to start the gearbox in potentially explosive atmospheres as specified by the **ATEX100a** directive.



**CHECK**

#### Before starting up

Inspect the packaging to check the goods upon delivery.

Make sure the following information given on the gearbox identification plate matches the approved values for use in an explosive atmosphere:  
anti-explosion category, anti-explosion zone, maximum surface temperature class.

Are you sure no oil, gas, acids, vapors, radiation will be present in the potentially explosive atmosphere when the gearbox is installed?

Does the environmental temperature correspond to the value given in the "Operating temperature" paragraph?

Make sure the gearboxes are well-ventilated and that there are no external heat sources (example through fittings). The temperature of the cooling air must never exceed 40 °C.

Does the installation position match the value given in the gearbox manual?

#### Warning!

**The position in which the gearbox is installed can be changed only after contacting the manufacturer. The gearbox shall not be considered in compliance with the ATEX directive if the manufacturer is not contacted.**

Does the correct oil level in the installation position correspond to the amount of oil stated in the gearbox manual?

Can the oil drain (where provided) and inspection plugs along with the release valves be easily reached?

Have the parts at the inlet and outlet been installed in compliance with the ATEX directive?

For motors driven by inverters: make certain the motor is certified for use with an inverter.

The inverter parameters must be set to prevent the gearbox from overloading.

## 5.3 DURING OPERATION

### Checks to be made

The charts given below list all the operations that have to be checked **while a gearbox is running** in potentially explosive atmospheres as specified by the **ATEX100a** directive.

### During operation



Measure the surface temperature after approximately three hours of operation.  
It **must not exceed 50 °C (differential value)** in relation to the room temperature.

If this temperature (differential value) is exceeded, immediately stop the gearbox and contact the manufacturer.



## 6 MAINTENANCE

The maintenance schedule includes routine and periodic operations. Routine maintenance refers to operations during which the operator and/or specially trained maintenance workers have to inspect and check the parts. When performing periodic maintenance the operators have to replace, adjust and lubricate parts. The manufacturer holds specific training courses and provides publications to fully instruct the maintenance staff on how to perform the jobs correctly and in complete safety.

### 6.1 ROUTINE AND SCHEDULED MAINTENANCE

Periodically check the outer surfaces of the gearbox and the cooling air passages for cleanliness. Regularly make sure that no lubricant leaks through the seals, mounting flanges, mounting screws of the covers, caps etc..

#### **Warning!**

**If the gearbox is run without enough lubricant, it may be seriously and often irreparably damaged.**

Efficiency of the heat exchange process is notably affected if the oil inside the gearbox is too low. As heat dissipation and the cooling capacity are considerably reduced, the inside operating temperature increases above all at the points where the sides of the teeth come into contact.

### 6.2 CLEANING

Clean the gearbox casing on a regular basis to assure good heat exchange with the outside.

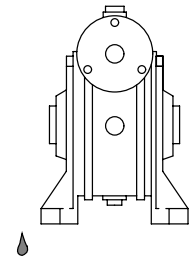

### 6.3 OPERATING TEMPERATURE

The operating temperature depends on a number of factors such as the type of power transmission, the type and quantity of lubricant, the characteristics and structure of the gearbox, the speed and power applied and the environment in which the gearbox is operating. When worm gearboxes are employed, the allowable temperature may range up to 50° higher than the room temperature considering that today all manufacturers are tending to make more and more compact gearboxes.

This means that as the gearboxes are smaller, they hold less lubricant which results in higher temperatures that they are not designed to withstand. With a standard worm gearbox, the maximum allowable inside temperature is 80 °C. Higher temperatures than this could cause damage, particularly to the ring seals.

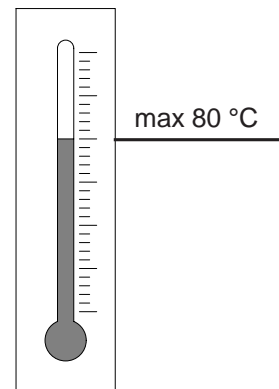

## 6.4 MEASURING THE OPERATING TEMPERATURE

Wherever possible, suitable instruments should be used to measure the external temperature of the gearbox housing. As, under regular operating conditions the temperature inside the gearbox increases 15 - 20 °C compared to the outside temperature, the housing normally becomes too hot to touch. It is therefore wrong to assume that the gearbox is too hot just because it cannot be touched. In fact, it cannot be touched as soon as the temperature goes above 50 °C. It is important to check that once the gearbox has reached the normal speed the operating temperature remains more or less constant under the same work conditions. This indicates that the gearbox is running in a trouble-free manner.

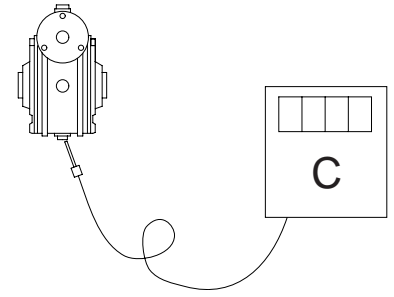

## 6.5 CHECKING THE LUBRICANT LEVEL

Regularly check that the oil level is correct when the gearbox has stopped and cooled down sufficiently. To do this, use the sight-glass provided. This should be kept clean and be see-through at all times. When looking through the sight-glass, if it seems as though there are deposits in the oil, make sure that no foreign bodies such as dust, sand or water have got inside the gearbox housing. If the oil level has fallen below the minimum level, top up immediately. If the gearbox is run without enough lubricant, it may be seriously and often irreparably damaged. Efficiency of the heat exchange process is notably affected if the oil inside the gearbox is too low. As heat dissipation and the cooling capacity are considerably reduced, the inside operating temperature increases above all at the points where the sides of the teeth come into contact.

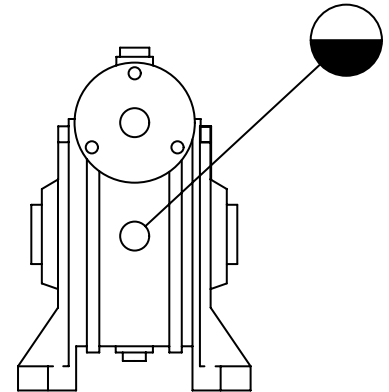

## 6.6 REPLACING THE SEALS

The efficiency and service life of the ring seals largely depends on the operating temperature in the contact zone, any chemical reactions which may occur between the rubber compound and the lubricant and, finally, its wear condition.

The ring seals need to be replaced when:

- the seal is no longer efficient and, as a result, oil is leaking out;
- the entire machine or system is overhauled.

Whenever a seal is no longer efficient, it must be replaced immediately to avoid any further leakage and prevent any other parts from being damaged.

When installing the new ring seal, follow the instructions below:

- take great care when handling the seal and make sure it is in good condition (do not leave it in stock for too long as this could cause premature wear especially if it is stored in a damp environment);
- always check that the seat where the seal is to be fitted is perfect i.e. without scoring, marks, nicks, dents or surface defects of any kind;
- make sure the lip of the new seal is not fitted at exactly the same point as the previous one;
- if the area where the ring seal comes into contact with the shaft has worn down by more than 0.2-0.3 mm, do not, under any circumstances, install a new seal but contact our local service centre where the staff will see whether the shaft can still be used and identify the cause of the damage;
- install the ring seal perpendicularly to the shaft, with the lip absolutely free and not curled under or pinched;
- install the ring seal so that the lip faces the oil that must be kept in or the side from where the pressure is exerted;
- for ring seals without a dust-tight lip, coat the outside of the lip with grease;
- for ring seals provided with a dust-tight lip, fill the gap between the seal lip and the dust-tight lip with grease;
- lubricate the seal seat on the shaft;
- do not use sealants because, if they get on the seal lip or shaft surface they can cause rapid wear;
- when installing the seal, press down as near as possible to the outside edge;

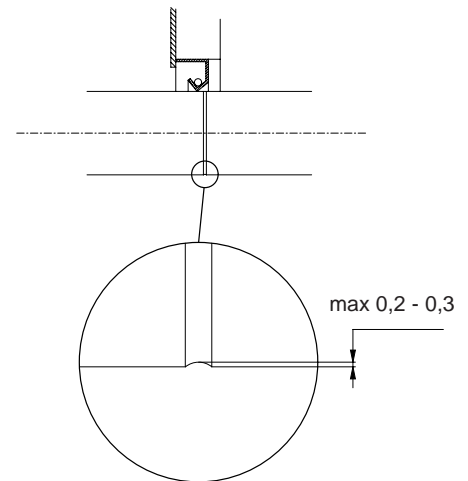

- do not block the ring seal axially or apply too much load;
- always use suitable tools to avoid damaging the seal lip with threads, grooves, sharp edges or keyways;
- always cover the seal lip and the seat on the shaft when repainting the gearbox.

All the precautions mentioned above need to be taken in order to prevent the ring seal from becoming dry especially when the shaft first starts to rotate. If the seal becomes dry, the temperatures in the area where it comes into contact with the shaft become too high immediately damaging the seal material and causing the lip to harden, crack and discolour.

## 6.7 LUBRICATION

All the U-MU and MD series worm gearboxes are delivered factory lubricated by SITI. They do not come with oil plugs as synthetic oil is used (I-MI series gearboxes are supplied factory lubricated up to size 90 included). This is considered a “life-long” lubricant, i.e. the gearbox does not require any maintenance. The use of oil instead of grease offers considerable improvements in terms of operation. In particular, it improves efficiency and lubrication when a very thin film of oil passes through the gears or when the gearbox is operated intermittently or temporarily but not under normal operating conditions. In addition, with oil, a much wider temperature range is possible, both as far as high and low temperatures are concerned. With synthetic oil, the minimum and maximum allowable operating temperatures no longer depend on the characteristics of the lubricant but on the properties of the material and the heat expansion of the aluminium. SITI uses **ISO VG 320** synthetic oil for the gearboxes.

On request, the worm gearboxes can be supplied with filler, drain and level plugs. The operator must fill the gearboxes with synthetic **ISO VG 320** oil as recommended by SITI. Check the oil level on a regular basis through the sight gauge. Fill up when necessary.

### A Gearboxes supplied with oil

Lubricating the gearboxes with synthetic oil ensures top performance, unlimited service life and minimum maintenance is required. In this case the only maintenance procedure to be performed is cleaning the outside of the gearbox housing with gentle solvents so as not to ruin the paintwork.

#### a) Running in the gearboxes

The running in time is about 300 hours. During this period we recommend gradually increasing the power up to a limit of 50-70% of the maximum power output (during the first hours of operation). At this stage the gearbox may reach higher temperatures than normal. The oil does not need to be changed after the running in period unless any dirt or particles of abrasive material are found which could affect the gearbox operations.

### B Gearboxes supplied without oil

The gearboxes supplied by our company without oil are the ones intended for heavy-duty use. In this case, the maintenance procedures to be performed are as follows:

#### a) Running in the gearboxes

The running in time is about 300-400 hours. During this period we recommend gradually increasing the power output up to a limit of 50-70% of the maximum power output (during the first hours of operation). At this stage the gearboxes may reach higher temperatures than normal. It is advisable to change the oil after the running in period.

#### b) Changing the oil

The time interval at which the oil should be changed depends on the operating conditions. These are outlined in the chart below.

The data indicated in this chart refers to mineral and synthetic lubricants. The latter can be used for long-term lubrication if used within a normal temperature range and as long as they are not ruined by dirt, air, etc. getting inside the gearbox.



Oil temperature	Duty	Changing time interval (hours)
< 60 °C	Continuous	5000
	Intermittent	8000
> 60 °C	Continuous	2500
	Intermittent	5000

**⚠ Warning!**

The lubricant must not be mixed with mineral oils and is not compatible with nitro-cellulose paints and latex gaskets.

**⚠ Warning!**

Before changing the oil, make sure the gearbox has come to a full stop and wait until the oil has cooled down to a temperature at which the operator does not risk getting burnt.

- Take off the plug.
- Drain the oil from the gearbox. Remember that oil greatly pollutes the environment.
- Use a container to collect the oil. Do not dispose of the oil in the environment.
- Add oil and put the plug back on.

**👉 Note**

Dispose of the oil in compliance with current environmental protection laws and standards.

## LUBRICANT AMOUNT CHARTS

Series I-MI	Pre-lubricated with ISO VG 320								To be added by client			
Size of gearbox	I 25	I 30	I 40	I 50	I 60	I 70	I 80	I 90	I 110	I 130	I 150	I 175
Amount of lubricant (litres)	0,035	0,035	0,160	0,240	0,190	0,500	0,950	1,925	3,600	3	7	7

Series U-MU	Pre-lubricated with synthetic oil ISO VG 320					
Size of gearbox	U 40	U 50	U 63	U 75	U90	U 110
Amount of lubricant (litres)	0,16	0,19	0,5	0,5	0,90	1,66

Series MD	Pre-lubricated with synthetic oil ISO VG 320			
Size of gearbox	MD 126	MD 160	MD 200	MD 250
Amount of lubricant (litres)	0,9	1,9	3,8	7,5

### Lubricating gear pairs

The primary reduction units supplied with motor installed are filled with oil. In all the other cases, the primary reduction units are supplied without lubricant, which is on customer's account.

#### Series U-MU gear pairs

Amount of oil for gear pairs	
Size	Liters
P63	0,075
P71	0,100
P80	0,150
P90	0,150

#### Series I-MI gear pairs

Amount of oil for gear pairs	
Size	Liters
P110	0,450



## 6.8 TIGHTENING TORQUE CHART

For gearboxes and accessories

<b>Screw threading Class 8.8</b>	<b>Cast and steel twisting moment (Nm)</b>	<b>Aluminium twisting moment (Nm)</b>
<b>M 4</b>	2,9	2,3
<b>M 5</b>	6	4,8
<b>M 6</b>	10	8
<b>M 8</b>	25	20
<b>M 10</b>	49	39
<b>M 12</b>	86	69
<b>M 14</b>	135	108
<b>M 16</b>	210	168
<b>M 18</b>	290	232
<b>M 20</b>	410	328

## 6.9 TROUBLESHOOTING GUIDE

This chart contains malfunctions that may arise during operation. They are listed according to the individual functions of the gearbox. The trouble, causes and part that may have caused the fault are indicated in the chart.

PROBLEM	POSSIBLE CAUSES	REMEDY
The motor does not start	<ul style="list-style-type: none"> <li>a) The motor's electrical wiring is faulty</li> <li>b) The motor is faulty</li> <li>c) Wrong size motor</li> </ul>	<ul style="list-style-type: none"> <li>a) Check the connections</li> <li>b) Replace the motor</li> <li>c) Replace the motor</li> </ul>
The motor and gearbox reach temperatures which are too high	<ul style="list-style-type: none"> <li>a) Mechanical overload</li> <li>b) Wrong size geared motor assembly</li> </ul>	<ul style="list-style-type: none"> <li>a) Check the mechanical parts driven by the geared motor assembly</li> <li>b) Replace the geared motor assembly</li> </ul>
The current absorbed and/or the temperature of the motor are too high	<ul style="list-style-type: none"> <li>a) Motor faulty</li> <li>b) Wrong size motor</li> </ul>	<ul style="list-style-type: none"> <li>a) Replace the motor</li> <li>b) Replace the motor</li> </ul>
The gearbox reaches a temperature which is too high	<ul style="list-style-type: none"> <li>a) Gearbox faulty</li> <li>b) Wrong size gearbox</li> <li>c) Wrong mounting position</li> <li>d) Not enough lubricant</li> </ul>	<ul style="list-style-type: none"> <li>a) Repair or replace the gearbox</li> <li>b) Replace the gearbox</li> <li>c) Check that the gearbox supplied is that ordered</li> <li>d) Add lubricant until the level indicated is reached</li> </ul>
Oil leaks from the shafts	<ul style="list-style-type: none"> <li>a) Ring seals worn down or defective</li> <li>b) Seal seat on the shaft worn</li> </ul>	<ul style="list-style-type: none"> <li>a) Replace the ring seals</li> <li>b) Replace the ring seals and install them in a very slightly different position or replace the shafts</li> </ul>
Oil leaks from the seals	<ul style="list-style-type: none"> <li>a) Flanges not tightened properly</li> <li>b) Seals defective</li> </ul>	<ul style="list-style-type: none"> <li>a) Tighten the flanges</li> <li>b) Replace the seals and check that the surfaces are properly machined</li> </ul>
The gearbox is making a banging noise.	<ul style="list-style-type: none"> <li>a) Gear teeth defective</li> </ul>	<ul style="list-style-type: none"> <li>a) Contact our customer service department</li> </ul>
The gearbox is whistling.	<ul style="list-style-type: none"> <li>a) Not enough lubricant</li> <li>b) Gears defective or worn down</li> <li>c) Bearings defective or not installed properly</li> </ul>	<ul style="list-style-type: none"> <li>a) Add lubricant until the level indicated is reached</li> <li>b) Contact our customer service department</li> <li>c) Contact our customer service department</li> </ul>

## 7 REPLACEMENT PARTS

If used properly and the scheduled maintenance is regularly performed as specified in this manual the gearboxes are designed and engineered not to require spare parts due to faults or break downs.

If some parts need to be replaced, use only original spare parts. The parts are to be removed and re-installed only by specially-trained authorized personnel.

**Along with voiding the warranty, use of non-original spare parts may also affect proper operation of the gearbox.**



# SITI SPA

SOCIETÀ ITALIANA TRASMISSIONI INDUSTRIALI



RIDUTTORI  
MOTORIDUTTORI  
VARIATORI CONTINUI  
MOTORI ELETTRICI C.A./C.C.  
GIUNTI ELASTICI

GEARBOXES  
GEARED MOTORS  
SPEED VARIATORS  
A.C./D.C. ELECTRIC MOTORS  
FLEXIBLE COUPLINGS



**ITALIA (ITALY)**  
**SEDE e STABILIMENTO**  
HEADQUARTERS

Via G. Di Vittorio, 4  
40050 Monteveglio - BO - Italy  
Tel. +39/051/6714811  
Fax. +39/051/6714858  
E-mail: [info@sitiriduttori.it](mailto:info@sitiriduttori.it)  
[commitalia@sitiriduttori.it](mailto:commitalia@sitiriduttori.it)  
[export@sitiriduttori.it](mailto:export@sitiriduttori.it)  
WebSite: [www.sitiriduttori.it](http://www.sitiriduttori.it)



**CINA (CHINA)**  
**SEDE e STABILIMENTO**  
OFFICE AND PLANT

Shang Hai SITI Power Transmission Co.,Ltd.  
No. 303 Kangliu Road Kangqiao Industrial Zone Pudong  
Shang Hai, P.R. China P.C.: 201315  
Tel. +86-21-68060500  
Fax. +86-21-68122539  
E-mail: [service@sh-siti.com](mailto:service@sh-siti.com)  
WebSite: [www.sh-siti.com](http://www.sh-siti.com)